

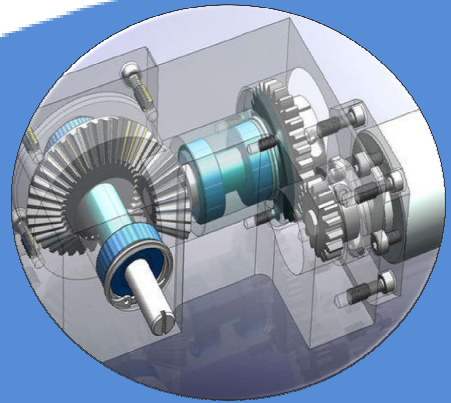

# AVNL Institute of Learning Ambarnath 421502

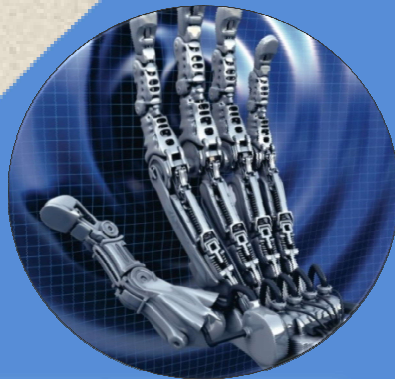

## 1.0 Preamble

AVNL Institute of Learning Ambernath (AVNLIOL) believes that investment in human resource offers much better returns than on any other type of investment. The focus of training is also on bringing about attitudinal changes that will obviously be more rewarding.

As a pioneering Institute, AVNLIOL Ambernath endeavor is to provide training in the latest and best technology subjects.

AVNLIOL Ambernath crafted courses which are not only technologically and academically relevant, which will not only develop the skill & knowledge of the participant, but will make him competent enough to translate the skill & knowledge so gained into viable inputs.

The courses conducted by AVNLIOL Ambernath cover the entire spectrum of activities from Design to Quality to Manufacturing to Marketing & Export to IPR with specialization in Patent Drafting & Filing to Industry 4.0 including Artificial Intelligence.

AVNLIOL Ambernath is working under General Manager with supporting 2 Group 'A' and 6 Group 'B' officers.

## 2.0 Introduction

AVNLIOL Ambernath is one of the 3 training institutes functioning under Armoured Vehicle Nigam Limited, Chennai, Tamilnadu, A Govt. of India Enterprise, Ministry of Defence from 01-10-2021.



*Inauguration of Institute by then Prime Minister of India Shri Jawaharlal Nehru*

AVNLIOL Ambernath was earlier known as *Artisan Training School*, has been a pioneer institute in 1950s imparting rigorous training in mechanical engineering trades. The artisans passing out from ATS spearheaded industrial progress in western region.

Later ATS Ambernath was renamed as *Regional Training Institute* and established in 1996 for imparting training to Group B & C officials of Ordnance Factories and their

Allied Establishments. RTI was renamed as *Ordnance Factories Institute of Learning* in the year 2005.

AVNLIOL Ambarnath has a glorious past and has redeemed itself time and again in the matters of human resource development.

### 3.0 Location:

AVNLIOL Ambarnath is located in the bustling suburbs of district Thane and in close proximity to the hub of industry.

AVNLIOL Ambarnath is located adjacent to Machine Tool Prototype Factory (MPF) in Ordnance Estate Ambarnath, Thane District of Maharashtra State on the Mumbai-Pune Railway line. Visitors and participants from outstation can alight at Kalyan, Thane, Kurla (LT Terminus), Dadar or Chhatrapati Shivaji Terminus (CST) from there local trains services can be availed to reach Ambarnath. Auto-rickshaws are available between Ambarnath and Ord. Estate.

Registered Office	Communication Address
Armoured Vehicles Nigam Limited HVF ROAD, AVADI, CHENNAI- 600 054 PHONE NO 044- 26383601, 044- 26384784 E-Mail: info@avn.co.in Website: avnl.co.in	AVNL Institute of Learning, Ambarnath A unit of Armoured Vehicles Nigam Limited, Ordnance Estate, Ambarnath (West) Dist-Thane, Maharastra - 421502 Phone 0251-2613605 Fax 0251-2613101 E-mail: ofilam-mod@nic.in iolamb@avn.co.in

**Mission:** Sustained development of human resource to turn them into valuable assets and torch bearers for organizational growth.

### Vision:

- Organize meaningful training programmes.
- Progressive up gradation of training courses, faculty, technology and infrastructure.
- Bring improvement in quality of work through attitudinal changes and value system.
- To up skill the students of ITIs, Polytechnic and Degree College to Industrial standards.

**4.0 Training:** AVNLIOL Ambarnath is organizing various types of training in consultation with MDO's of factories like:

- a) **Long Term Courses:** 12 week courses are conducted for direct recruit JWM/CM. They are given intensive training on Organizational Awareness other Allied Establishments, various procedures in the field of Administration, Material Management, Quality, Production, Planning Control, IT and Design etc. 4-6 week courses for LDCE/promote JWM/CM also refresher courses for other employees on need basis.

b) **Core-Competence Areas:** Short term core courses organized on Core areas of institute are as under:

- Mechanical Maintenance
- Mechanical Design
- Mechatronics
- Fuze Technology
- B-Vehicle



This institute also conduct specialized courses on the following topics:

- Industry 4.0
- Python Programming
- Arduino Programming
- Cyber Security
- Sensor Technology
- HTML, CSS, JavaScript, PHP
- Maintenance aspects of Plant and Machinery
- Intellectual Property Rights
- DTS and DOT Courses

c) **Courses in other areas:** Apart from the above courses in Core Competence Areas, AVNLIOL Ambarnath conducts courses in the following areas.

- Information Technology
- Material Management
- Administration
- Quality Management
- ISO 9000, EMS
- Industrial Safety & Pollution Control

d) Workshops and Seminars are organized by institute time to time on Hydraulics, Pneumatics & Mechatronics.

e) **Skill Development:**

- a. Short Term Courses are conducted for ITI instructors nominated by **Directorate of Vocational Education and Training, Govt. of Maharashtra** on chargeable basis. Total 665 instructors are selected to train in this financial year. Till date 135 instructors from different ITI's of Maharashtra were trained. Courses designed are as under:

- AutoCAD for Mechanical/Electrical/Civil
- Hydraulics & Pneumatics

Practical Demonstration of Robotic Kit to Participants

- Automation and Sensor
  - HTML CSS & JavaScript
- b. Short Term Courses are conducted for students of nearby ITI, School & Colleges on charging minimum fees. This training is practical oriented and industry based syllabus. Courses are as under:
- AutoCAD for Mechanical/Electrical/Civil
  - Hydraulics & Pneumatics
  - HTML CSS & JavaScript
  - PHP server side scripting
  - Automation and Sensor



E-Class- 65 inch display, Android based Interactive panel with features of Touch screen , Internet connectivity , Wi-Fi ,Inbuilt Audio Video Systems.

### 5.0 Other highlights of Training:

- ✓ Dedicated and well experienced faculties.
- ✓ Well prepared Course Material incorporating latest information on the subjects.
- ✓ Visit to Industries for certain courses for acquiring first-hand information pertaining to technological changes.
- ✓ Extensive practical sessions for certain courses.
- ✓ Open sessions for exchanging information and sharing of experiences.
- ✓ Faculty Bank: A huge bank of expert faculty in various fields is available with institute. Regular interval assessment of faculties also carried out.
- ✓ Feedback: All the participants, individually, give feedback on each topic taught with Excellent/Very Good/Good/Average on point system for the faculty and course contents.
- ✓ Pre & Post-training assessment are carried out for every short term course & only post training assessment for long term courses in order to assess the improvement gained by participants in their knowledge/skill after attending the course and meritorious incumbents for each course are awarded merit certificates and cash award/memento.

**6.0 Laboratory:** This institute has infrastructure for ideal learning. It has laboratories like:

- ✓ Design Lab (E-class)
- ✓ IT Lab
- ✓ Hydraulic and Pneumatic Lab.

**7.0 Training Kit:** A brief description of training kits available in lab is as under:

- ✓ Electro-hydraulics training system with P.L.C & H.M.I

Electro-Hydraulic training kit consists of Pump, Control valves and Actuators .Electro Hydraulic training setup-Relay Ports, PLC- I/O port, HMI, VFD etc. for demonstration hydraulic practical's



Electro- Pneumatics training kit consists of Compressor, FRL , Control valves and Actuators .Electro Pneumatic training setup-Relay Ports, PLC- I/O port, HMI, etc. for demonstration Pneumatic practical's

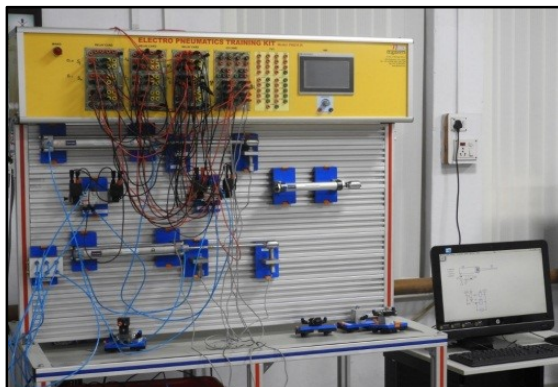

- ✓ Electro-pneumatics training system with P.L.C & H.M.I
- ✓ Advance Pneumatic Kit
- ✓ LVDT Training Kit
- ✓ Atal Tinkering Package 1- includes Microcontroller kits (Arduino), Single Board Computer (Raspberry Pi), Sensors, Actuators, Display boards, Servo Motors, DC motors etc.
- ✓ Robotic Arms, Humanoids Robots (DIY Kit)

- ✓ Simulation software to aid in study of design and working of circuits

**8.0 Teaching Aids:** In addition, the lab is equipped with various teaching aids to support the study of components and systems for better understanding and visualization as given below:

- ✓ Schematic diagrams/symbols and cut-sections of components for circuit building exercises and to study the inner construction of components respectively.
- ✓ Ergonomic furniture, projector and white board for conducting theory sessions and practical, thereon for quick understanding and grasp of fundamentals to save time.
- ✓ E-Class room with 20 computers and Interactive board is available for various design related programs.
- ✓ IT Lab has a setup of 30 computers to undertake various training classes.

## 9.0 Infrastructure

a) *4 Modern Class Room with*

- ✓ Fully 3 star air-conditioned
- ✓ Modern teaching aids
- ✓ Ergonomic furniture
- ✓ Acoustics control
- ✓ Audio Podium
- ✓ Soothing LED Lights



b) *Library:*

- ✓ 4,500 volumes of Technical and Non-Technical books.
- ✓ Lifetime membership of National Digital Library (NDL) from IIT Khargpur
- ✓ Technical Monthly subscription from CMTI, Bangalore



The library consists of books of different areas viz. Metallurgical, Mechanical, Electrical, Design, Production Maintenance, Quality etc. It also consist of books related to Accounting, Administration, Safety etc

c) *Auditorium* Seating Capacity: 213



Auditorium Hall for the purpose of Seminars, Inauguration, Valediction etc. This Auditorium hall is fully Air-conditioned and equipped with modern sound Systems, ergonomic furnitures etc.

d) **Lodging and Boarding:** in hostel total 50 rooms are available with dual sharing. Following facilities are provided in hostel

- ✓ General Amenities
- ✓ LED Lights
- ✓ LED TVs
- ✓ Messing
- ✓ Recreation Room
- ✓ Gymnasium
- ✓ Outdoor Sports
- ✓ Solar Hot water
- ✓ RO/UV Filtered Water
- ✓ Lush Green Lawns





Well -furnished room with facilities like LED TV , Almirahs, Chairs, Beds, Tables , AC with attached washroom



Fully air- conditioned Dining Hall with capacity of 50. It is having an attached kitchen and serving area. Water chiller with purifier is also available.



Fully Equipped Volleyball court with light facility to play in night.

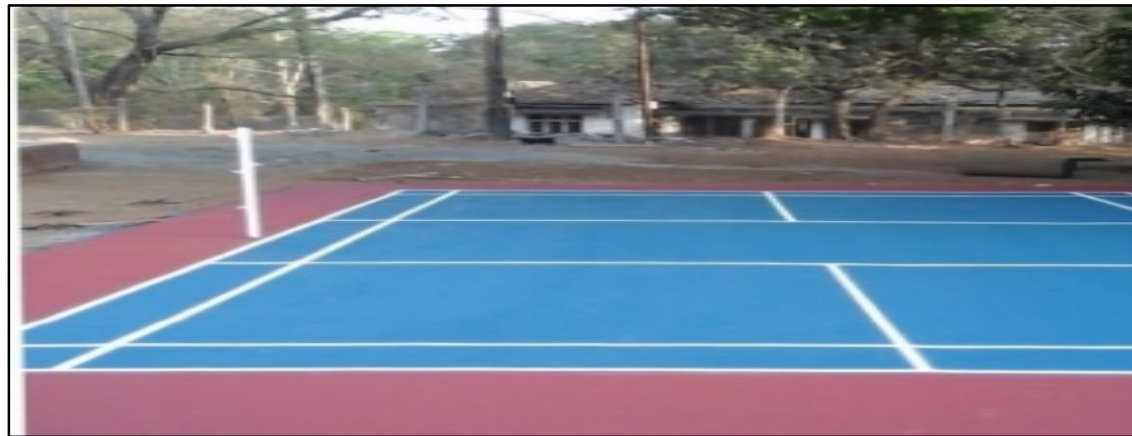

Badminton Court with three layer wooden base.



Basketball cum Tennis Court



Recreation hall for participants with facility of playing Carom, chess etc.



Table Tennis



Fully Air- Conditioned Gym

**10.0 In-house Journal:** A Bi-Monthly Publication of In-House E-magazine in Hindi named as 'Pratibimb' is published.

**11.0 Certification:** AVNLIOLAM is certified institute of "Quality Management System ISO 9001: 2015".

**12.0 Training Achievements:**  
For Ordnance Factory employees.

Particulars	2019-20	2020-21	2021-22 upto Dec'21
Total no of Courses	74	73	74
Total no of Participants	1619	1492	1485

For outside participants as skill development initiative:

Particulars	2019-20	2020-21	2021-22 upto Dec'21
Total no of Courses	07	05	19
Total no of Participants	117	60	378
Revenue	54,750/-	45,100/-	2,95,050/-

**13.0 Future Planning & Targets:**

a) Center of Excellence: To be earmark as "Center of Excellence" in the field of Hydraulics & Pneumatics and in Mechatronics.

1. Hydraulics and Pneumatics: This institute is having lab facilities with PLC based Electro Hydraulic and Electro Pneumatic Kit along with Valves and other components, it required further enhancement with servo systems kits.

*In this regard, after fulfilling the requirements as per Proforma along with Detailed Project Report and other relevant documents, this institute applied for Center of Excellence in the field of Hydraulics & Pneumatics on 30/11/2021 to Ministry of Skill Development Enterprises, New Delhi.*

2. Mechatronics- This is the field which integrate Mechanical system with Electronics controls. It Includes sensors, Actuators and Controls Systems. Presently we have some sensors kits only. To demonstrate the working of Mechatronic systems we require the Automation kit which consisting modern sensors, controls systems integrate with PLC and other communication systems.

b) Memorandum of Understanding:

Each AVNL IOL shall seek to be recognised as reputed Training Institutes by signing MOUs for mutual collaboration with other reputed Institutes / Organizations for mutual collaboration, consultancy, research, and exchange of faculty etc., in the domain of Training and Development.

This Institute has signed MOU with following Institutes / Organizations.

- Signed MOU with M/s Federation of Indian Industries Thane Manufacturing Association, Wagle Industrial Estate Thane.
- Signed MOU with Govt. Industrial Training Institute (I.T.I) in Maharashtra State (MS, India) having its registered office at Ambernath Town.

c) Specialization: AVNL/HR has mandated this institute to conduct comprehensive and certification courses for employees of AVNL and other newly formed DPSUs in the following area:

1. Finance, Accounts, Audit systems and procedures: This is a seven week comprehensive online course for participants of 7 new DPSUs` of erstwhile OFB from 17/01/2022 to 04/03/2022. The first five weeks course content basically covers existing CGDA Finance and Accounts procedures. The last two weeks course content covers Corporate Finance and Accounting procedures. The course will be conducted Online through Virtual platform of Cisco WebEx.
2. Material Management (Stores/Inventory Control, Procurement, GeM, Contract Management): This is a four week comprehensive online course for participants of 7 new DPSUs` of erstwhile OFB. Course will be scheduled in the month of April/May` 2022. The course will be conducted Online through Virtual platform of Cisco WebEx.
3. Other Core Technical Areas: This institute decided to arrange courses in following areas:
  - i) AutoCAD 2014
  - ii) Hydraulics & Pneumatics
  - iii) Mechatronics

All above three courses are of four week comprehensive online course for participants of 7 new DPSUs` of erstwhile OFB. Course will be scheduled in the month of April/May` 2022.

- d) Registration with Government e-Marketplace as a seller to offer our courses to other Government department.
- e) Energy conservation: Audit of institute and hostel by certifying agency. Possibilities will be explored in minimising consumption of electricity and water.

**14.0 Achievements and Awards:** Due to enormous efforts in imparting continuously effective training to the participants of various courses with excellent infrastructure and appreciable hostel arrangement, this institute has been awarded as the Best OFIL for the year:

- ✓ 2005-2006, jointly with OFIL Khamaria.
- ✓ 2007-2008, jointly with OFIL Avadi.
- ✓ Presented with “Best Efficiency trophy” for the year 2013.
- ✓ Presented with “Best Efficiency trophy” for the year 2016.
- ✓ Presented with “Best Efficiency trophy” for the year 2018.



- ✓ OFIL Ambarnath was awarded “First prize” for the implementation of Rajbhasha for the year 2013.
- ✓ OFIL Ambarnath was also awarded “Consolation prize” for Rajbhasha Exhibition Running Shield in the year 2014.



- ✓ Awarded by “Rajbhasha Chal Vaijanti Shield” from Nagar Rajbhasha Committee 2020-21



- ✓ Appreciation from Govt. of Maharashtra, ITI Ambarnath for conducting Industry Oriented Training Courses to Students and Instructors



GOVERNMENT OF MAHARASHTRA  
INDUSTRIAL TRAINING INSTITUTE, AMBERNATH  
OLD-BHENDIPADA, KALYAN-BADLAPUR ROAD, AMBERNATH DIST. THANE- 421501  
www.itiambernath.gov.in E-mail it0073ambarnath@gmail.com Phone-02512610937

OUT.NO. ITIABH/TRG/2021/2901

DATE 24/11/2021

To  
AVNL Institute of Learning  
Ambarnath - 421502

Sub: - Letter of Appreciation for conducting Industry Oriented Training Courses.

Dear Sir,

This is to place on record our gratitude to your Institute to conduct following training courses for our Trainees and Trainers on various occasions as per our requirement.

Course Name :- 1) Hydraulics and Pneumatics  
2) Auto CAD  
3) Microcontroller 8051  
4) Python Programming

We have gathered from the feedback given by the participants that our Trainees and Trainers immensely liked Class Room atmosphere and way of knowledge sharing of faculties. Participants learn a lot from the invaluable insights of faculties shared with them.

We once again thank you and look forward to your continuous association with our organization.

Yours sincerely,

(Ajit P. Shinde)

Principal  
ITI, Ambarnath Dist. Thane  
Ambarnath

